

A perforated rather than insulated ceramic band with a cowl, plenum and blower is designed for use on plastic extrusion equipment where the process generates excessive heat. When a predetermined temperature is exceeded, the blower will engage, cooling the process.

Features:

- Replaces most O.E.M. type assemblies
 - Easy to Install
- Long life Ceramic Heater Bands Standard
 - Cast Aluminum & Mica Bands available
 - Hinged Shroud
- Recommended Wattage: 30 watts sq/in.
 - Recommended Voltage: 230Volts (can be wired for 460/480V)
- Blower voltage: 120V standard (240V available)
 - Thermocouple hole: please specify location
- Shroud OD approximately 3" larger than barrel
 - Spacing between ceramic bands 1"-1 1/2"
 - Ceramic Heaters sheath: Perforated (to aid in air cooling)
 - One piece ceramic band standard
 - Number of heater determined by size of blower assembly

TO PLACE AN ORDER, PLEASE SPECIFY:

- INSIDE DIAMETER
- WIDTH
- TYPE OF TERMINATION AND LOCATION
- WATTS AND VOLTS
- SKETCH OR DRAWING IF NECESSARY

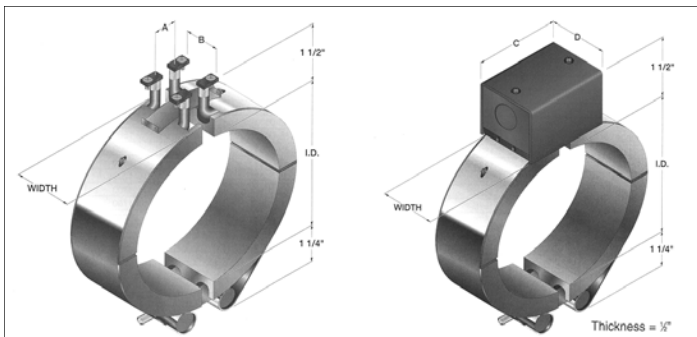

TEVAC
ALUMA-SHOE BAND HEATER

The ALUMA-SHOE band incorporates a tubular heater set pressed in a grooved aluminum extrusion. It offers a quick responding band heater with uniform sheath temperatures.

- EXCELLENT HEAT TRANSFER
- RUGGED LONG LASTING DESIGN
- VIRTUALLY CONTAMINATION PROOF
- UNIFORM SHEATH TEMPERATURE
 - EASY INSTALLATION

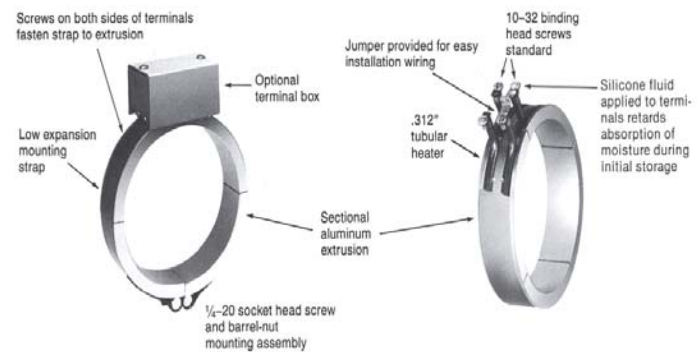

DIMENSION REFERENCE	1-1/2" WIDE	2-1/2" WIDE	3" WIDE	4" WIDE
A	1"	1-1/2"	1-1/2"	2"
B	3/4"	1-13/16"	2"	3-1/4"
C	3-3/8"	4"	4"	4"
D	2"	2-3/4"	3-5/8"	4-1/4"
E	2"	2-3/8"	2-3/8"	3-3/8"

COOLING TUBES
 STAINLESS STEEL
 OR COPPER
 AVAILABLE

DIAMETERS
 FROM 3-1/2" & UP.
 3/4" WIDE ALSO
 AVAILABLE