

Tevac Part Number	Nominal Size	Threads Tap / Inch	Length (L)	Hex Size (S)
BP-18	1/8	27	.250	3/16
BP-14	1/4	18	.406	1/4
BP-38	3/8	18	.406	5/16
BP-12	1/2	14	.531	3/8
BP-34	3/4	14	.531	9/16
BP-10	1	11-1/2	.656	5/8

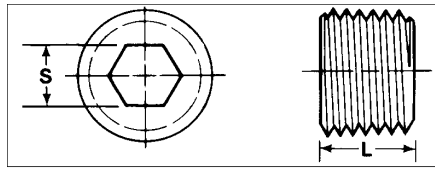

High Pressure Seal: Dry seal thread formed with 7/8 Taper per foot. Install in standard 3/4 TPF tapped hole.

OTHER SIZES ARE AVAILABLE

TEVAC BRASS PRESSURE PLUGS

TEVAC'S Brass Pressure Plugs give high-pressure seal through a deliberate difference to taper between the plug and the tapped hole. Flush seating is achieved through closer control of thread forms, sizes, and taper.

Tevac Part Number	Nominal Size	Length (L)	Hex Size (S)	Drill Size (D)
BTP-1/8	1/8	.50	5/64	11/32
BTP-1/8 OS	1/8	.50	5/64	23/64
BTP-1/4	1/4	.56	1/8	7/16
BTP-1/4 OS	1/4	.56	1/8	29/64
BTP-3/8	3/8	.62	1/8	9/16
BTP-3/8 OS	3/8	.62	1/8	37/64
BTP-1/2	1/2	.62	1/8	11/16
BTP-1/2 OS	1/2	.62	1/8	45/64

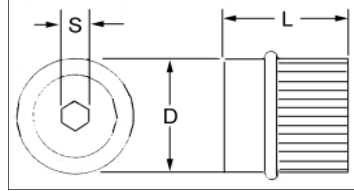

TEVAC THREADLESS BRASS PRESSURE PLUGS

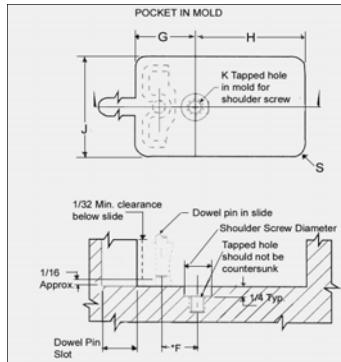
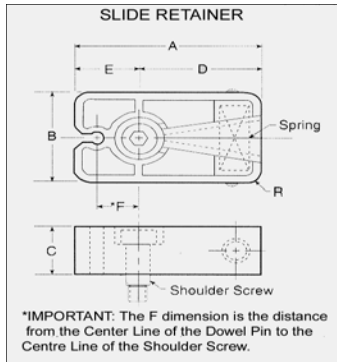

TEVAC'S SLIDE RETAINERS

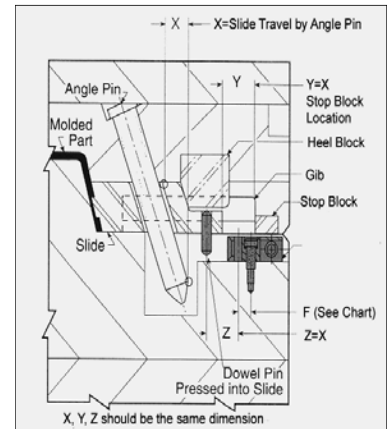

TEVAC'S Slide Retainers provide a compact method of slide retention that eliminates the use of springs or costly hydraulic systems. Interference with machine tie bars or safety gates is eliminated because the Slide Retainer can be installed behind or below the slide. They are made of case hardened steel and available in 3 sizes for slides up to 22, 44 and 88 pounds. They can also be used in multiples for larger or heavier slides. All Slide retainers come supplied with dowel pin, spring and shoulder screw.

Tevac Part No.	A Dim	B Dim.	C Dim.	D Dim.	E Dim.	*F Dim.	R Rad	Dowel Pin Dia.	Lgth	Max. Slide Weight	G Dim.	H Dim.	J Dim.	K Depth	Shoulder Screw Dia.	Lgth.	S Rad
SLR-1	1-1/2"	3/4"	.63	.89	.61	.360	.19	.250	1-1/4"	22 lbs	.73	1.01	1.00	10-24x1/2DP	.250	.625	.31
SLR-2	2-1/8"	1-1/4"	.79	1.31	.81	.500	.25	.312	1-1/2"	44 lbs	.93	1.43	1.50	1/4-20x1/2DP	.312	.750	.37
SLR-3	3-3/8"	1-3/4"	1.18	2.08	1.30	.800	.38	.375	2-1/4"	88 lbs	1.42	2.20	2.00	5/16-18x5/8DP	.375	1.00000	.50

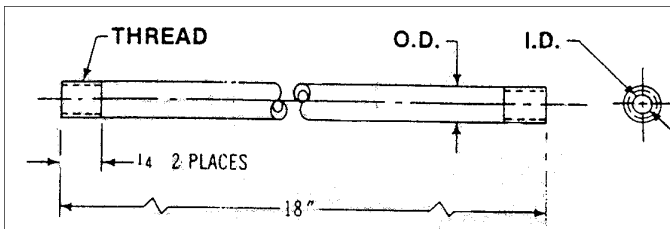

BRASS BUBBLER TUBES

Tevac Part Number	O.D.	I.D.	Thread	Channel Diameter
BT-105	.125	.069	No. 5-44	.144
BT-210	.190	.126	No. 10-32	.228
BT-340	.250	.170	1/4-28	.302
BT-450	.312	.214	5/16-24	.377
BT-570	.437	.307	7/16-20	.531

TEVAC'S BUBBLER TUBES

TEVAC'S Bubbler Tubes are used for cooling cores in molds or dies. They are supplied threaded at both ends, thus permitting two threaded tubes to be cut from the 18" length supplied. They can be used as replacement tubes in Cascade Water Junctions.

STAINLESS STEEL BUBBLER TUBES

Tevac Part Number	O.D.	I.D.	Thread	Channel Diameter
BTS-100	.093	.078	NONE	.120
BTS-105	.125	.069	No. 5-44	.144
BTS-210	.190	.126	No. 10-32	.228
BTS-340	.250	.170	1/4-28	.302
BTS-450	.312	.214	5/16-24	.377