

OPTION 1

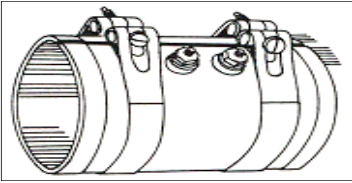

Barrel Nut Strap – Standard Heater Construction. High torque clamping straps provide superior heat transfer and greatest heater life; should be used whenever possible. Flexible strap locating allows for easier installation.

OPTION 2

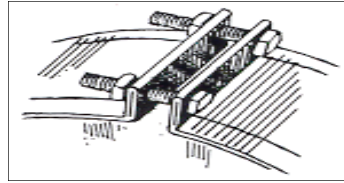

Clamping Tabs – Are available for applications where straps impede openings for instrumentation. However, high-torque clamping straps provide superior heat transfer and should be used whenever possible.

OPTION 3

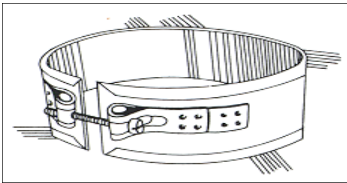

Integral Straps — attached straps eliminate strap loss. Especially helpful on large, 2 piece bands, where installation of heater and separate strap may be awkward. Stainless steel outer sheath provides low expansion clamping pressure across the entire heater surface.

OPTION 4

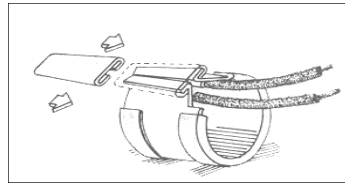

Wedge Lock — provides low profile clamping where space is limited and can not be used. Available in Type 3 or 4 leads.



TEVAC DESIGN OPTIONS

ONE PIECE

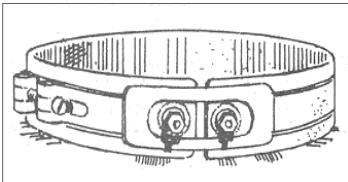

Standard Construction
The 1pc design allows for continuous windings of the resistance ribbon with minimal cold sections along the diameter of the band.

TWO PIECE

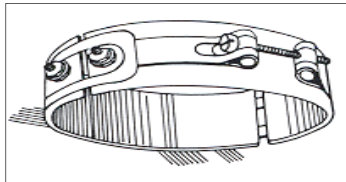

Two Piece Bands can be easily installed over a cylinder rather than slipped on from the end. Specify the line voltage and wattage per half. Available in all lead options.

E-EXPANDABLE

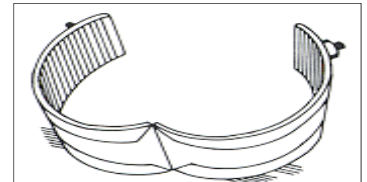

Expandable Bands are designed to be opened and closed for quick installation. They are shipped open and **should not be opened or closed more than twice.** Available in all lead options.

H-HOLE

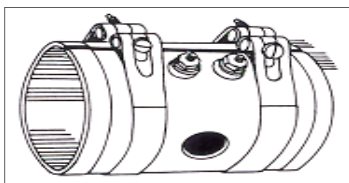

Holes, Cut-Outs & Notches
Provide clearance for T/C probes, bolts, etc. Specify hole locations in degrees from center of gap. For critical locations provide sample band or detailed drawing. Available in all lead options. In many cases an oversized gap can eliminate the need for special holes.

IR-IRREGULAR SHAPE

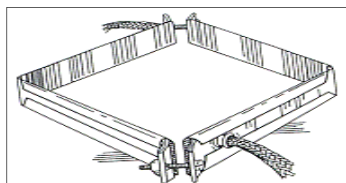

Hexagonal, Rectangular, Square, or Irregular Shaped Heaters - offered for special shaped dies and applications. 1 or 2pc construction is available.

TMN-T/C MOUNTING NUT

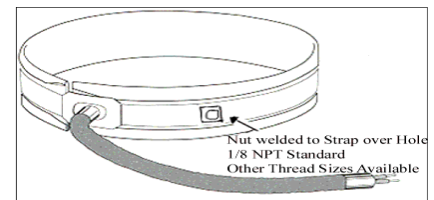

T/C Mounting Brackets- available for attachment to the heater band strap to hold the T/C sensor in place. Specify location. 1/8 NPT thread size standard, other NPT sizes available.

**MANY HEATERS
IN STOCK!**

TEVAC LEAD OPTIONS

TYPE 1

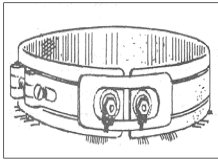

Post Terminals 1 on 1 with 10-32 threads are securely fastened to each end of the resistance winding with a unique posi-weld connection.

TYPE 2

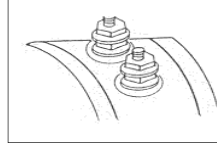

2 on 1 In Line Post Terminals are available on any construction or clamping variation. Recommended for narrow band heaters where post terminals are preferred and terminal box protection is required.

TYPE 2A

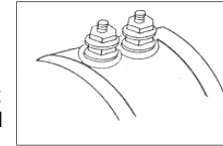

2 on 1 Side by Side Post Terminals are available on any construction or clamping variation. Standard on band heaters over 3" wide and for terminal box protection.

TYPE 3

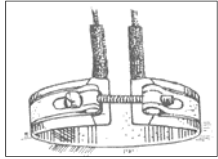

Dual Protective Fiberglass Sleeve Leads are the most common lead arrangement for nozzle heater application. High temperature flexible lead wire exits the unit through a protective fiberglass sleeve & the side adjacent to each end. The sheath encloses both ends to protect against molten plastics & other contaminants.

TYPE 4

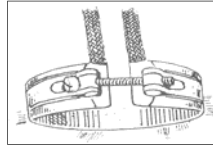

Dual Stainless Steel Braid is designed for additional protection against molten plastics and abrasion. High temperature flexible leads are individually covered with a stainless steel braid which exits the heater through the side similar to type 3.

TYPE 5

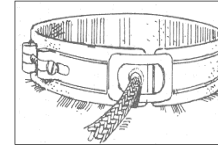

Single Stainless Steel Braid lead arrangement offers excellent abrasion resistance and provides for simple wiring installation. The high flexible leads exit together near the end of the band through a protective flange and a single SS Braid.

TYPE 6

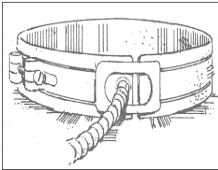

Stainless Steel Hose offers the greatest resistance to heat, moisture, and abrasion while remaining flexible. Locating leads exit near one end of the band.

TYPE 7

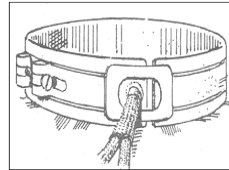

Protective Flange and a Single Fiberglass Sleeve is recommended for applications where abrasion resistance is not a factor. The leads exit the heater one end of the band.

TYPE 8

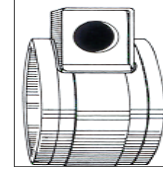

Terminal Boxes are used to protect exposed terminals. Knock outs and threaded holes are available for armor cable or conduit connections. Minimum band diameter is 3". Type 1 post terminals are under terminal box.

TYPE 10

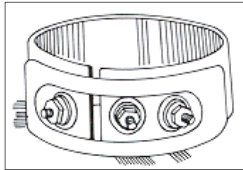

Terminal Lead Construction is available to provide dual voltage, three phase, three zone operation, or act as a ground. Available in all lock-up options.

TYPE 11

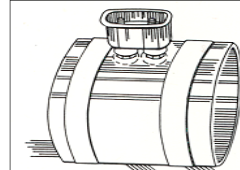

European Plugs allow for quick disconnect and replacement of heaters on foreign manufactured machinery. The standard plug is 2 pin, 240 volt and 15 amps.

TEVAC'S SUGGESTIONS FOR LONG HEATER BAND LIFE

The cylinder to be heated should be clean and smooth for good heat transfer between the band and cylinder. Air gaps can cause "hot spots", resulting in shortened heater life. TEVAC'S Band Heaters when installed should be tightened, then tapped with a soft mallet to help "snug" the band to the cylinder. Tighten again after tapping. Once the heater has been operated for a short time, retighten the heater band after it has cooled. Check regularly to maintain a tight fit. One piece heaters should not be opened too wide to prevent internal damage. If a one piece can not be slid on, then a two-piece or expandable band is recommended. The ideal wattage calculation should allow the heater to operate with a minimal amount of on-off cycling. Proper temperature control and sensing can improve heater life considerably. TEVAC'S Band Heaters are designed to withstand considerable abuse and contamination. However, care should be taken to protect lead connection and minimize contaminants that could cause the heater to carbonize and fail prematurely.

TO PLACE AN ORDER, PLEASE SPECIFY:

- QUANTITY
- INSIDE DIAMETER
- WIDTH
- VOLTAGE – on two piece bands, each piece to be rated at the operating voltage.
 - WATTAGE – on two piece bands, specify total wattage.
 - BASIC CONSTRUCTION AND OPTIONS
 - PART # – if known or previously ordered.
 - GAP – if other than factory determined minimum.
 - LEAD LENGTH

TEVAC CERAMIC HEATERS STYLES

Four Styles to Choose From:

STANDARD -5/8" Thick; 1/4" Thermal Insulation; Long Life; Lower Energy Costs; Hi-temps-Up to 1400°F; Easy Installation; Efficient in Wide Widths; Fewer Bands per Installation. "THE PREFERRED CHOICE OF O.E.M.'s"

INSULATION PLUS® - 7/8" Thick; An Additional 1/4" Thermal Insulation in a Separate Channel; Total 1 1/2" Insulation; Energy savings Up To 30%; Cooler Ambient Temperatures. "THE ENERGY SAVER"

SUPER INSULATION PLUS-1-1/4" Thick; 7/8" Total Insulation Built-In; Eliminate Blankets and Insulated Shrouds or Use (Less Expensive) Un-Insulated Shrouds. "MAX. ENERGY SAVINGS, MIN. SHEATH TEMPS"

ULTRA THIN LINE - Maximum 3/8" Thick; Low Mass; Quick Response for Critical High-Temp Molding Operations; Up to 1400°F and 60 Watts/Sq. In. "NEW ULTRA-THIN LINE"

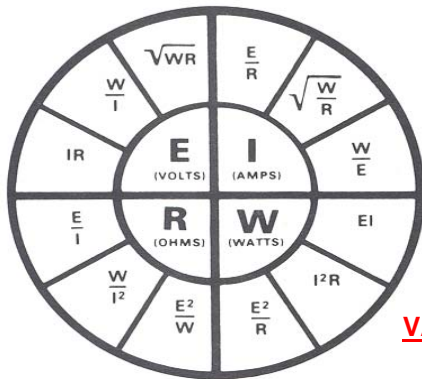
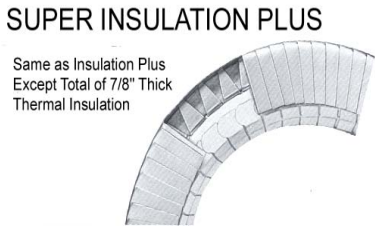
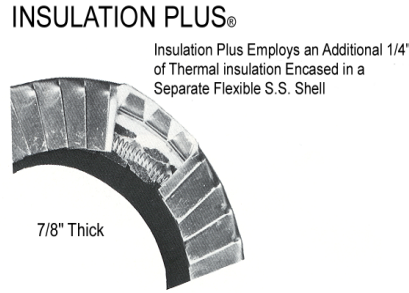
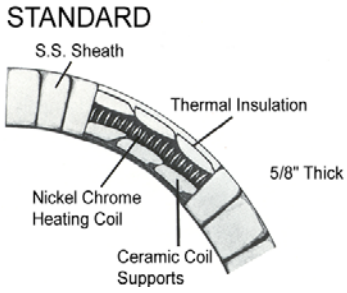

DETERMINING HEATER WATTAGE:

Suggested watt density is 40 to 45 w/in² for ceramic heater bands.
 To determine heater wattage multiply 3.14 x I.D. x width.

SPECIFICATIONS:

- Expandable, will open fully to fit around barrel O.D.
- 5/8" high lock-up flanges standard or barrel nut clamp optional at no charge
- 1/4-20 post terminals located 180° from gap
- Total wall thickness 5/8"
- All stainless steel sheath

TO PLACE AN ORDER, PLEASE SPECIFY:

- 1) Ceramic heater band, standard construction
- 2) Inside diameter x width
- 3) Voltage and wattage
- 4) Lock-up option: Flange, barrel nut clamp, or latch and trunion
- 5) Post terminals or other type
- 6) Terminal box if required



The standard ceramic insulated band has been, and continues to be, the only *barrel* heater having built-in thermal insulation. In the past, machine manufacturers have elected to use the heater because of several advantages, but rarely for its heat conserving qualities.

The present energy situation (in which the plastic processor must bare exorbitant costs) is the reason for the development of the "INSULATION PLUS" ceramic band heater.

The "INSULATION PLUS" ceramic band heater consists of the standard ceramic band components with 1/8" ceramic fiber insulation plus an additional insulation chamber 1/4" thick all of which is contained in a single flexible sheath.

This additional chamber dramatically reduces power consumption, in comparison to ALL other non-insulated band heaters.

INSULATION PLUS EMPLOYS AN ADDITIONAL 1/4-" OF HIGH DENSITY CERAMIC-FIBER INSULATION ENCASED IN A SEPARATE FLEXIBLE STAINLESS STEEL SHELL. THE INSULATION IS NOT COMPRESSED WHICH PROVIDES MAXIMUM VALUE

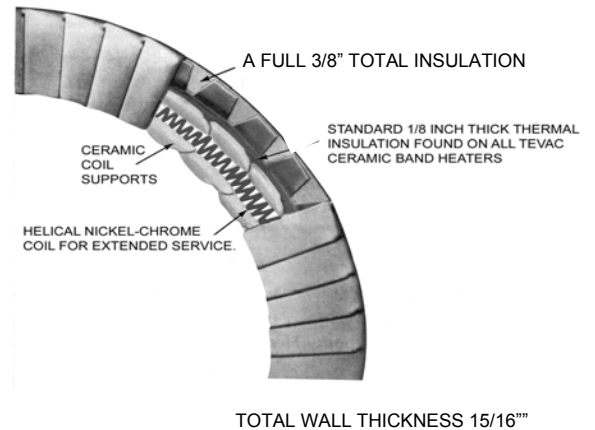

TO PLACE AN ORDER, PLEASE SPECIFY:

- 1) Insulated plus design
- 2) Inside diameter x width
- 3) Voltage and wattage
- 4) Lock-up option, flange or barrel nut clamp
- 5) Post Terminals or other type
- 6) Terminal box if required

LOCK-UP OPTIONS

Flange Type
 Barrel Nut Clamp
 Latch and Trunion Quick Release Spring Loaded
 (Suggested for Bands 12" I.D. and Over)

WIRING OPTIONS

Single Phase
 Dual Voltage
 2 Circuit Bands
 3 Phase

TEVAC CERAMIC HEATER BANDS OPTIONS

FLEXIBLE LEAD OPTIONS
INSTALLED ON POST TERMINALS

Flex. Leads in Strain Relief Bracket Exiting from Heater Sheath
 BX or Metal Braid over Flex. Lead Wire
 Flex. Leads exiting from Edge of Heater Band

TERMINAL OPTIONS

Post Terminal
 Terminal Box: (Std. Or Low Profile)
 Grounding Stud in Sheath

THERMOCOUPLE CLEARANCE
HOLES OPTION

In Gap
 In Element Area

SHEATH FEATURE OPTIONS

Stainless Steel Inner Liner
 Shell Overlap Covering Gap
 Perforated Metal Sheath (Air Cooled Heater)
 Metric Sizes

TO PLACE AN ORDER, PLEASE SPECIFY:

- STANDARD OR INSULATION PLUS®
- INSIDE DIAMETER X WIDTH
- VOLTAGE AND WATTAGE
- LOCK-UP OPTIONS
- POST TERMINALS
- TERMINAL BOX IF REQUIRED
- THERMOCOUPLE HOLE AND LOCATION
- FLEXIBLE LEAD OPTIONS
- WIRING OPTIONS
- SHEATH FEATURE OPTIONS

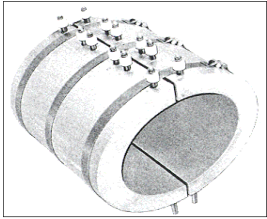

Cylindrical Heat & Heat/Cool
For Extrusion Machines

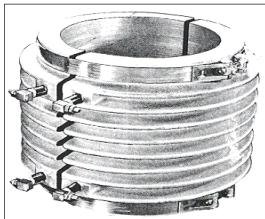

Finned for Air Cool
Extrusion Machines

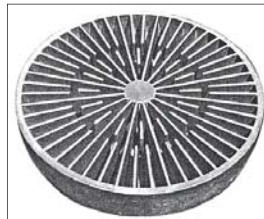

Special for Your
Heating Requirements

HOLES, CUTOUTS AND
THERMOWELLS AVAILABLE.

JUST SPECIFY SIZE AND LOCATION.

CUSTOMIZED TO YOUR APPLICATION.



Protective Housing Options

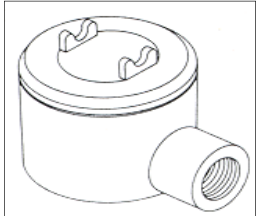

Explosion Proof Box
OPTION 1

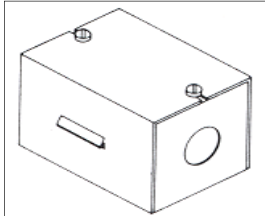

Sheet Metal Box
OPTION 2

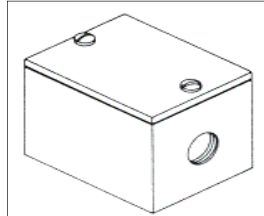

Cast In Box
OPTION 3

Electrical Termination

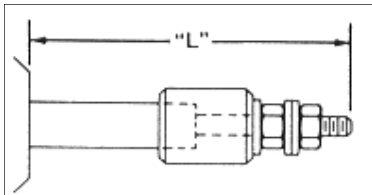

ET TYPE 1
Ceramic Insulated
10-32 Screw Terminal
(Other Types Available)

Cooling Tube Terminations

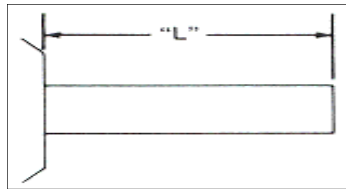

CT TYPE 1
Plain

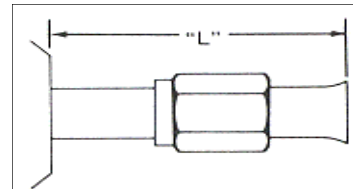

CT TYPE 2
37° Flare Nut Fitting

(OTHER TYPES AVAILABLE)

Cylindrical Heat & Cool

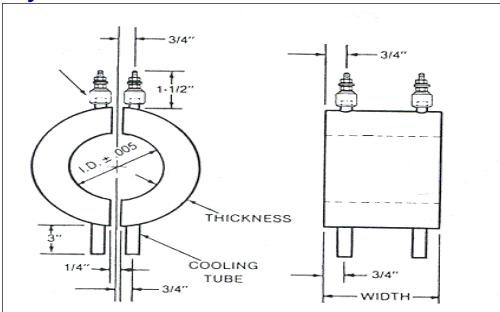

Cylindrical Heat with Fins

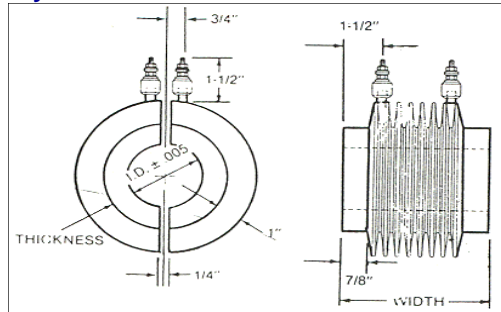

TO PLACE AN ORDER, PLEASE SPECIFY:

- **CAST DESIGN.** PLEASE SUPPLY A COMPLETE DRAWING WHICH SHOWS ALL DIMENSIONS AND CRITICAL TOLERANCES. ALSO, **INCLUDE SIZE AND LOCATION OF ANY HOLES, CUTOUTS OR THERMOWELLS.** REFER TO REFERENCE DIMENSIONS AND SPECIFICATIONS ABOVE.
- **EXIT LOCATIONS** OF HEATER ELEMENT AND COOLING TUBE (IF REQUIRED)
- **ELECTRICAL TERMINATIONS AND HOUSINGS;** TYPE S IS STANDARD
- WATTAGE AND VOLTAGE RATINGS
- ALUMINUM OR BRONZE
- QUANTITY

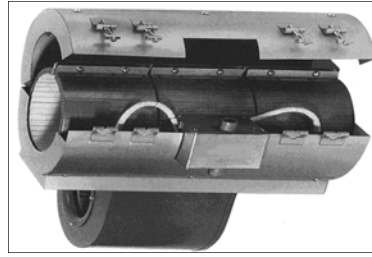
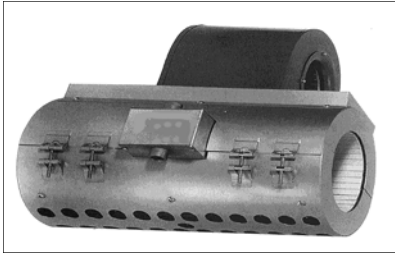

A perforated rather than insulated ceramic band with a cowl, plenum and blower is designed for use on plastic extrusion equipment where the process generates excessive heat. When a predetermined temperature is exceeded, the blower will engage, cooling the process.

Features:

- Replaces most O.E.M. type assemblies
 - Easy to Install
- Long life Ceramic Heater Bands Standard
 - Cast Aluminum & Mica Bands available
 - Hinged Shroud
- Recommended Wattage: 30 watts sq/in.
 - Recommended Voltage: 230Volts (can be wired for 460/480V)
- Blower voltage: 120V standard (240V available)
 - Thermocouple hole: please specify location
- Shroud OD approximately 3" larger than barrel
 - Spacing between ceramic bands 1"-1 1/2"
 - Ceramic Heaters sheath: Perforated (to aid in air cooling)
 - One piece ceramic band standard
 - Number of heater determined by size of blower assembly

TO PLACE AN ORDER, PLEASE SPECIFY:

- INSIDE DIAMETER
- WIDTH
- TYPE OF TERMINATION AND LOCATION
- WATTS AND VOLTS
- SKETCH OR DRAWING IF NECESSARY

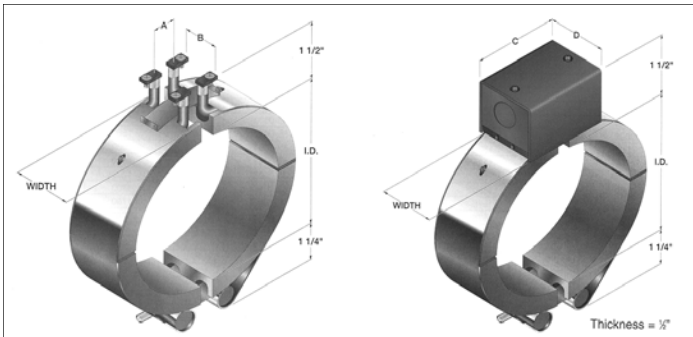

TEVAC
ALUMA-SHOE BAND HEATER

The ALUMA-SHOE band incorporates a tubular heater set pressed in a grooved aluminum extrusion. It offers a quick responding band heater with uniform sheath temperatures.

- EXCELLENT HEAT TRANSFER
- RUGGED LONG LASTING DESIGN
- VIRTUALLY CONTAMINATION PROOF
- UNIFORM SHEATH TEMPERATURE
 - EASY INSTALLATION

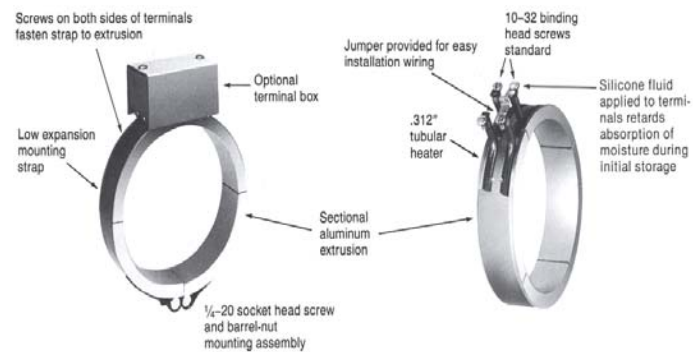

DIMENSION REFERENCE	1-1/2" WIDE	2-1/2" WIDE	3" WIDE	4" WIDE
A	1"	1-1/2"	1-1/2"	2"
B	3/4"	1-13/16"	2"	3-1/4"
C	3-3/8"	4"	4"	4"
D	2"	2-3/4"	3-5/8"	4-1/4"
E	2"	2-3/8"	2-3/8"	3-3/8"

COOLING TUBES
 STAINLESS STEEL
 OR COPPER
 AVAILABLE

DIAMETERS
 FROM 3-1/2" & UP.
 3/4" WIDE ALSO
 AVAILABLE

TEVAC's VERY HIGH TEMP

VERY HIGH TEMP WIRE - 842° F (450°C) TYPE MG

GAUGE	STRANDING	AMPACITY*	TEVAC PART NUMBER
22	7 x 30	14	VHTW-22
20	10 x 30	19	VHTW-20
18	16 x 30	26	VHTW-18
16	26 x 30	34	VHTW-16
14	41 x 30	45	VHTW-14
12	65 x 30	65	VHTW-12
10	105 x 30	85	VHTW-10



DESCRIPTION: Flexible 27% Nickel -plated copper, insulation of glass tape/mica, jacketed with glass braid and teflon saturant overall.

AVAILABLE IN :
50 FT COIL
100 FT COIL
250 FT COIL
500 FT COIL

* Ampacity based on maximum conductor temperature of 450° C in free air at ambient temperature of 30° C.

TEVAC's HIGH TEMP WIRE
FOR BAND & CARTRIDGE HEATERS

HIGH TEMP WIRE - 482° F (250°C) TYPE TGGT

GAUGE	STRANDING	AMPACITY*	TEVAC PART NUMBER
22	7 x 30	12	HTW-22
20	10 x 30	16	HTW-20
18	16 x 30	23	HTW-18
16	26 x 30	40	HTW-16
14	41 x 30	53	HTW-14
12	65 x 30	70	HTW-12
10	105 x 30	93	HTW-10



DESCRIPTION: Flexible stranded nickel-plated copper, TFE Teflon tape. Fiberglass

AVAILABLE IN :
50 FT COIL
100 FT COIL
250 FT COIL
500 FT COIL

* Ampacity based on maximum conductor temperature of 250° C in free air at ambient temperature of 30° C.

WIRE LUGS

WIRE SIZE	STUD SIZE	STUD DIAMETER	HOLE	TEVAC PART NUMBER
22-18	10	.198	---	TL-22
22-18	10	.198	1/4-20 hole	TL-22-1/4
16-14	10	.198	---	TL-16
16-14	10	.198	1/4-20 hole	TL-16-1/4
12-10	10	.198	---	TL-12
12-10	10	.198	1/4-20 hole	TL-12-1/4

AVAILABLE IN :
50 PCS
100 PCS
250 PCS
500 PCS

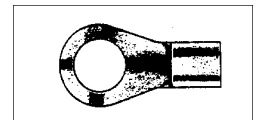

900° F High Temperature Terminal Lugs

TEVAC's WIRE LUGS

BUTT CONNECTORS



WIRE SIZE	TEVAC PART NUMBER
22-18	BC-22
16-14	BC-16
12-10	BC-12

AVAILABLE IN :
50 PCS
100 PCS
200 PCS
500 PCS

900°F Butt Connectors (Non-Insulated)

TEVAC's BUTT CONNECTORS, FIBERGLASS TAPE & CERAMIC TERMINAL COVERS

FIBERGLASS TAPE

TEVAC'S HI-TEMP FIBERGLASS TAPE ADHESIVE	
TEVAC PART NUMBER	For protective covering of band heater wiring 180°C continuous use service with dielectric strength rated at 2500 Volts. 3/4" Wide x 66 feet long per roll.
FT-75	

CERAMIC TERMINAL COVERS

THREAD SIZE	TEVAC PART NUMBER
10-24	CTC
10-32	CTC-1
1/4-20	CTC-2

MANY ITEMS IN STOCK FOR IMMEDIATE DELIVERY!