

Cylindrical Heat & Heat/Cool
For Extrusion Machines

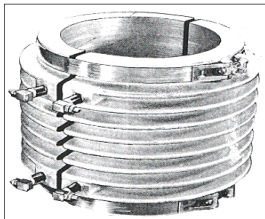

Finned for Air Cool
Extrusion Machines

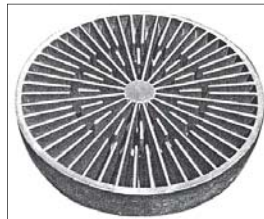

Special for Your
Heating Requirements

HOLES, CUTOUTS AND
THERMOWELLS AVAILABLE.

JUST SPECIFY SIZE AND LOCATION.

CUSTOMIZED TO YOUR APPLICATION.



Protective Housing Options

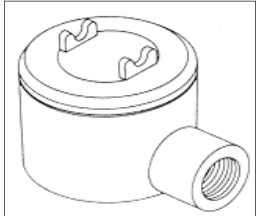

Explosion Proof Box
OPTION 1

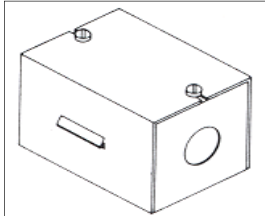

Sheet Metal Box
OPTION 2

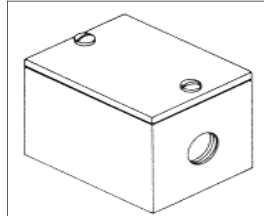

Cast In Box
OPTION 3

Electrical Termination

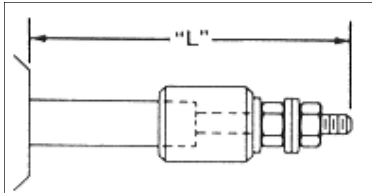

ET TYPE 1
Ceramic Insulated
10-32 Screw Terminal
(Other Types Available)

Cooling Tube Terminations

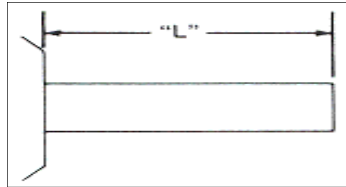

CT TYPE 1
Plain

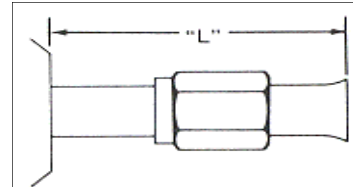

CT TYPE 2
37° Flare Nut Fitting

(OTHER TYPES AVAILABLE)

Cylindrical Heat & Cool

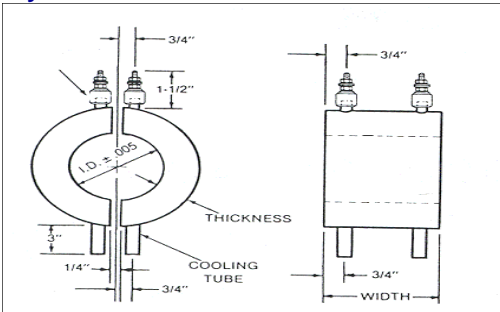

Cylindrical Heat with Fins

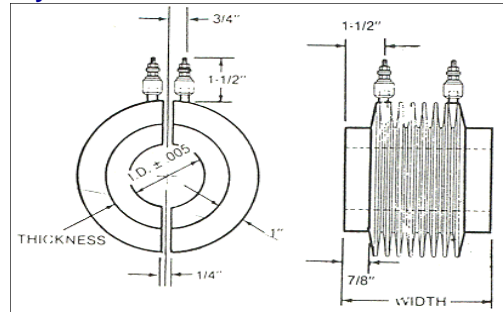

TO PLACE AN ORDER, PLEASE SPECIFY:

- **CAST DESIGN.** PLEASE SUPPLY A COMPLETE DRAWING WHICH SHOWS ALL DIMENSIONS AND CRITICAL TOLERANCES. ALSO, **INCLUDE SIZE AND LOCATION OF ANY HOLES, CUTOUTS OR THERMOWELLS.** REFER TO REFERENCE DIMENSIONS AND SPECIFICATIONS ABOVE.
- **EXIT LOCATIONS** OF HEATER ELEMENT AND COOLING TUBE (IF REQUIRED)
- **ELECTRICAL TERMINATIONS AND HOUSINGS;** TYPE S IS STANDARD
- WATTAGE AND VOLTAGE RATINGS
- ALUMINUM OR BRONZE
- QUANTITY